

PHERASTar: A Next Generation Multimode Plate Reader for Sophisticated HTS Assays

Marjan Orban¹, Silke Angersbach¹, Randy Hoffman² and Megan Buros²
¹ BMG LABTECH, Germany; ² Invitrogen Corporation, USA

Application Note 126

Rev. 02/2005



- Far Red PolarScreen™ assay for tyrosine kinase in low volume 384-well plates
- AlphaScreen™ assay for tyrosine kinase and cAMP in small volume 384-well plates
- HTRF® assay for TNF α in microplate formats up to 1536-wells

Introduction

The High-Throughput Screening (HTS) approach to drug discovery has gained widespread popularity over the last 15 years. Because of the need to process thousands of assays per day, HTS relied upon multiple-well microplates and robotic processing technologies. Pressure for increase in throughput and reduction in cost led to the adoption of high-density, lower-volume microplates as well as fast, homogeneous, miniaturizable screening assays. BMG LABTECH's PHERASTar combines rapid plate reading necessary for HTS with enhanced performance and sensitivity needed to read small liquid volumes (Fig. 1).



Fig. 1: The new multimode microplate reader PHERASTar is designed to perform HTS assays in plate formats up to 1536-wells.

This new multimode microplate reader has the flexibility to excel with the most demanding assays and is designed to read all leading HTS detection modes (fluorescence intensity, time-resolved fluorescence, fluorescence polarization, luminescence and absorbance) in all formats up to 1536.

The PHERASTar has been applied to a number of assays, including protein-protein binding, ligand-receptor binding, enzyme activity assays, molecular biological applications and second messenger quantification. The performance and features of the PHERASTar are presented in this application note with commercially available HTS kits such as Far Red PolarScreen™, AlphaScreen™, and HTRF®.

Materials and Methods

The detection system is a lens-based dual-channel photomultiplier configuration with five optimized photomultipliers that features simultaneous dual emission detection in all measurement modes except absorbance. This new optical design of the PHERASTar offers focus adjustment, minimal read times and allows ratiometric assays to be carried out at the highest possible level of performance (Fig. 2).

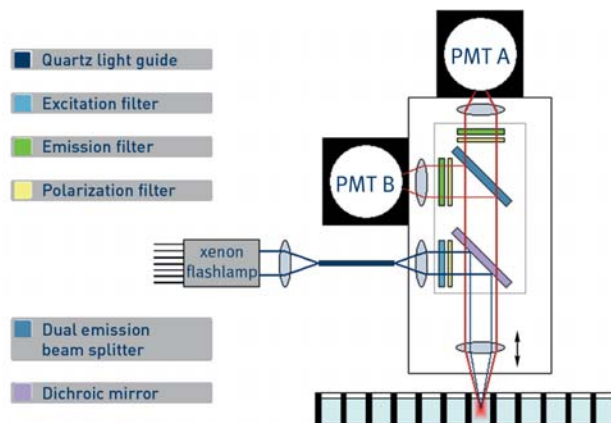

Fig. 2: New optical design of the PHERASTar

The following different HTS kits have been performed on the PHERASTar according to their particular application. The measurement techniques involved are fluorescence polarization (FP), AlphaScreen™, and time-resolved fluorescence in various plate formats up to 1536-wells.

In fluorescence polarization mode, the Far Red PolarScreen™ assay (# PV3327, Invitrogen, USA) for tyrosine kinase (Csk) was used in low volume 384-well plates (#3676, Corning, USA) with a final assay volume of 20 μ L according to the kit protocol.¹ The Far Red fluorophore was excited with 200 flashes at 610 nm and emission was detected in both polarization planes simultaneously at 670 nm.

Two assays were performed in AlphaScreen™ mode on the PHERASTar, the P-Tyr-100 (Phosphotyrosine) assay kit (#6760620, PerkinElmer, USA) and cAMP assay kit (#6760625, PerkinElmer, USA). All assays were performed in accordance with the kit protocols in white 384-well small volume (SV) plates (#784075, Greiner Bio-One, Germany) with a final assay volume of either 17 μ L or 25 μ L.² The AlphaScreen™ beads were excited with 400 flashes at 680 nm and emission was detected simultaneously in the range of 520 nm to 620 nm. To avoid evaporation, all plates were sealed with transparent microplate sealers (#77400-05, BMG LABTECH, UK) during incubation or storage and the sealer was not removed during reading of the microplate.

The time-resolved fluorescence mode was explored using the HTRF® reader control kit (#62RCLPEA, Cisbio, France) that is designed for the calibration of HTRF® compatible readers.³ Results were obtained in black 96-well half area plates (#3694, Costar, USA), 384-well small volume plates (#784076, Greiner Bio-One, Germany) and 1536-well plates (#782076, Greiner Bio-One, Germany) according to the kit protocol. The incubation took place overnight at room temperature and the final assay volumes were 100 μ L in the 96-well plate, 20 μ L in the 384-well plate and 7 μ L in the 1536-well plate. The kit is based on a Tumor Necrosis Factor alpha (TNF α) assay and may also be used for reader validations. Therefore, a comparison of the PHERASTar with BMG LABTECH's dedicated time-resolved fluorescence reader, the RUBYStar, was performed in 96-well and 384-well formats. On the flashlamp-based PHERASTar, the assays were run with 200 or 400 flashes per well and on the laser-based RUBYStar, the assays were performed with 20 flashes. The FRET donor europium cryptate was excited at 337 nm and emission was simultaneously read at 620 nm and 665 nm on both readers.

Results and Discussion

Far Red PolarScreen™ Kinase Assay:

Invitrogen's new Far Red PolarScreen™ assays employ a proprietary Far Red fluorophore in homogeneous fluorescence polarization assays. The fluorophore is highly water soluble and, unlike cyanine-based fluorophores, has a fluorescence lifetime that allows for large polarization shifts between free and bound tracer.

Protein kinases (PKs) are a diverse group of enzymes involved in many areas of cell signalling. These include cell growth and proliferation and neural functions. The keen interest in PKs arises from their role in regulating biological mechanisms. Through phosphorylation, PKs participate in many cellular signal transduction processes. Furthermore, defects in these pathways have been implicated in numerous human diseases including cancer, inflammation and diabetes. Research focused on kinase activity could ultimately identify targets that can be used to develop new pharmaceutical agents to treat many of these diseases.

Fluorescence polarization is a powerful tool with applications in kinase research: FP kinase assays are homogeneous and are amenable to miniaturization, and therefore quite useful in HTS applications. Because FP reports a molecule's tumbling rate, the polarization value relates directly to the molecular volume of the fluorescent molecule. An increase in molecular volume will slow a fluorescent molecule's tumbling rate and yield a high polarization value. Conversely, a decrease in molecular volume will increase the fluorescent molecule's tumbling rate and yield a lower polarization value.

In a Far Red kinase assay, kinase, substrate, and ATP are allowed to react in the presence of library compounds. After the reaction is complete, antibody and Far Red labelled tracer are added. The antibody can associate with either the labelled tracer (resulting in a high FP value) or the kinase-produced phosphorylated substrate (resulting in a lower FP value). The amount of antibody that binds to the tracer is inversely related to the amount of phosphorylated product present, and in this manner, kinase activity can be detected and measured by a decrease in FP value. Thus, library compounds that inhibit the reaction are identified as wells that have a high polarization value.

To demonstrate the use of the PHERAstar with Invitrogen's Far Red PolarScreen™ kinase assay, a tyrosine kinase (Csk) titration curve ($n = 3$) was performed, in the concentration range of 0.5 $\mu\text{g}/\text{mL}$ to 2 $\mu\text{g}/\text{mL}$ Csk, as shown in Fig. 3. During the fluorescence polarization measurement, the Far Red fluorophore was excited at 610 nm and emission was detected at 670 nm in both polarization planes simultaneously.

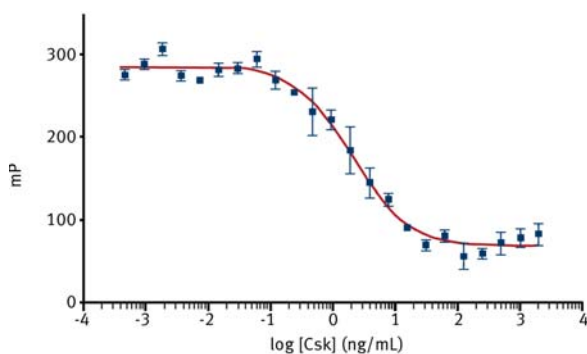

Fig. 3: Tyrosine kinase (Csk) titration with the PolarScreen™ Far Red detection kit on the PHERAstar.

Through this specific PolarScreen™ Far Red kinase assay example, we have shown that the PHERAstar can produce high quality fluorescence polarization data amenable to screening efforts. Far Red kinase assays can be used for both high-throughput screening, as well as further investigation of potential leads to determine accurate EC_{50} values.

AlphaScreen™ assays:

Homogeneous time-resolved AlphaScreen™ assays rely on the use of donor and acceptor beads. When a biomolecular interaction brings the beads into proximity, a cascade of chemical reactions is initiated to produce a greatly amplified luminescence signal in the range of 520 nm – 620 nm. An emission spectrum well below the excitation wavelength of 680 nm and other beneficial properties allow good signal separation between excitation and emission wavelengths.

AlphaScreen™ Phosphotyrosine (P-Tyr-100) assay – detection assay

The AlphaScreen™ P-Tyr-100 assay is based on a sandwich assay principle. After tyrosine kinase phosphorylation, a biotinylated polypeptide substrate is sandwiched between streptavidin-coated donor beads and anti-phosphotyrosine antibody P-Tyr-100 conjugated acceptor beads. Phosphorylation of the peptide by the tyrosine kinase results in an increase of the luminescence signal.

To demonstrate the functionality of the AlphaScreen™ assays and the performance on the PHERAstar, a titration curve ($n = 3$) with biotinylated phosphorylated polypeptide (b-LCK-P) was performed (Fig. 4).

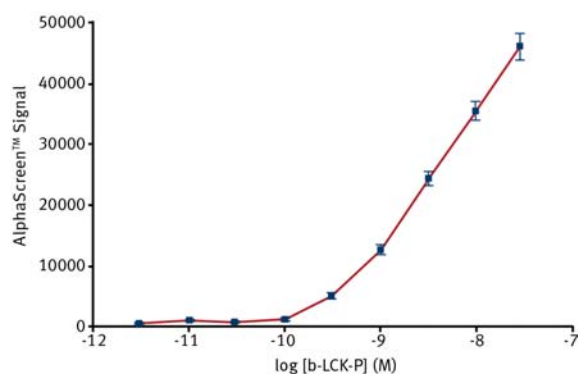

Fig. 4: A typical biotinylated-LCK-P AlphaScreen™ titration curve on the PHERAstar.

Plates were read on the PHERAstar after 1 hour incubation at room temperature with an integration time of 0.5 second per well. The concentration of b-LCK-P was in the range of 3 pM to 30 nM and the final assay volume 17 μL per well. The results of the assay very closely corresponded to the titration curve published in the kit protocol.² In order to show the well to well variation, the same assay has been performed with 48 replicates at a single b-LCK-P concentration (10 nM) and a control (without b-LCK-P) as shown in Fig. 5.

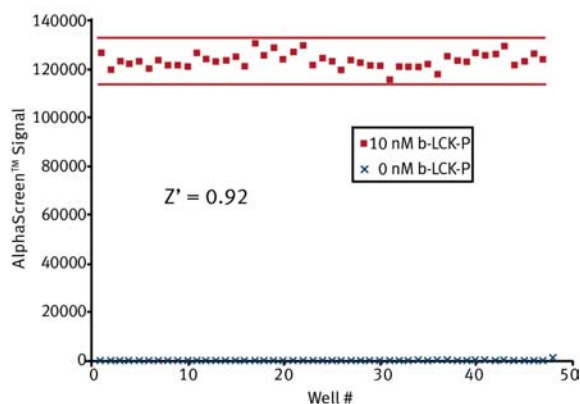

Fig. 5: A representative Z' -factor value of 0.92 was generated with 48 replicates in a 384-well format for the AlphaScreen™ assay.

As a characteristic parameter for the quality of the assay, a Z' -factor value of 0.92 was calculated, which represents excellent assay performance in a 384-well SV plate with 17 μL final assay volume. Z' -factor scores between 0.5 and 1 indicate a highly robust screening assay and in addition reflect the high quality of the instrumentation.⁴

AlphaScreen™ cAMP assay – competition assay

Cyclic AMP (cAMP) is one of the most important intracellular mediators. In many instances of G-protein-coupled receptor (GPCR) activation, a major class of target in the drug discovery process, adenylate cyclase is stimulated to convert AMP to cAMP. Cyclic AMP is then involved in regulatory processes such as protein kinase activation or ion channel gating. The determination of cAMP is therefore an essential tool for monitoring both agonist and antagonist activities on GPCRs.

Detection of cAMP with AlphaScreen™ is based on the competition between cAMP produced by cells and a biotinylated cAMP probe that is sandwiched by streptavidin-donor and anti-cAMP antibody conjugated acceptor beads. A decrease in signal is observed with an increase in intracellular cAMP produced. In the absence of intracellular cAMP, a maximum signal is detected. To demonstrate the functionality of the AlphaScreen™ assays and the performance of the PHERAstar, a titration curve (n = 3) with cAMP was performed (Fig. 6).

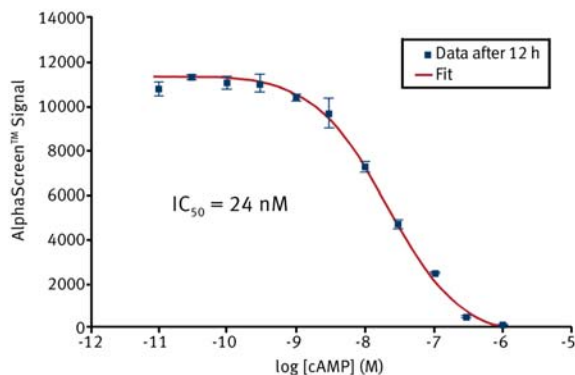

Fig. 6: A typical cAMP AlphaScreen™ titration curve on the PHERAstar.

Final assay volume was 25 µL per well in a 384-well SV plate and after 12 hours incubation at room temperature the plate was read on PHERAstar using an integration time of 0.5 seconds per well. The concentration of cAMP was in the range of 1 µM to 10 pM and the cAMP titration curve reveals a high S/B = 82 value. BMG LABTECH's evaluation software, including a 4-parameter-fit function, was used for curve fit and IC₅₀ determination. The calculated IC₅₀ = 24 nM value complies with the value reported in the literature.⁵

These experimental evaluations show that the PHERAstar can produce high quality data for the AlphaScreen™ assay technology and proves that laser-based instruments are not the only instruments on the market capable of reading AlphaScreen™ with satisfactory results. In fact, while performing these evaluations we discovered that laser-based instruments “bleach” the beads during a single read making rapid re-readings of questionable results impossible. With PHERAstar it is possible to focus adjust and re-read a plate several times without loss in absolute signal or sensitivity (Fig. 7).

Ten consecutive PHERAstar measurements were performed within one hour in a 384-well SV plate containing 43 replicates of the assay. The signal of the first AlphaScreen™ measurement was normalized to 100%. The following readings show a constant signal of 99.3% ± 1.6%. The robustness of the data is indicated by a Z'-factor value of 0.90.

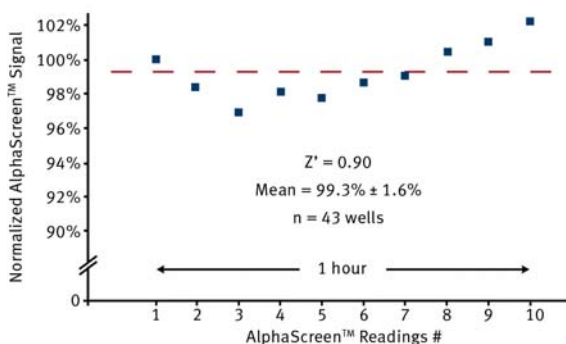

Fig. 7: Even after ten readings of the same AlphaScreen™ plate on the PHERAstar, absolute signal and sensitivity remain constant. There is no “bleaching” effect detectable.

HTRF® TNFα immunoassay:

Cisbio's HTRF® assays employ fluorescent Eu³⁺ cryptates (donor) and XL665 (acceptor) in homogeneous time-resolved FRET-based assays. Upon excitation, when the two entities come into close proximity, FRET can occur and XL665 re-emits a specific long-lived fluorescence at 665 nm, in addition to the donor emission at 620 nm.

Tumor Necrosis Factor alpha (TNFα), a 17 kDa cytokine, is an important mediator secreted by activated macrophages and monocytes with a large spectrum of antiviral immunoregulation, metabolic and inflammatory properties. This factor is cytotoxic for some tumor cell lines *in vitro* and causes the necrosis of certain tumors *in vivo*. TNFα acts via binding to specific cell surface receptors.

The HTRF® TNFα assay is a single step double-site immunometric assay involving two MABs conjugated either with europium cryptate or to XL665. The HTRF® TNFα assay principle is shown in Fig. 8.

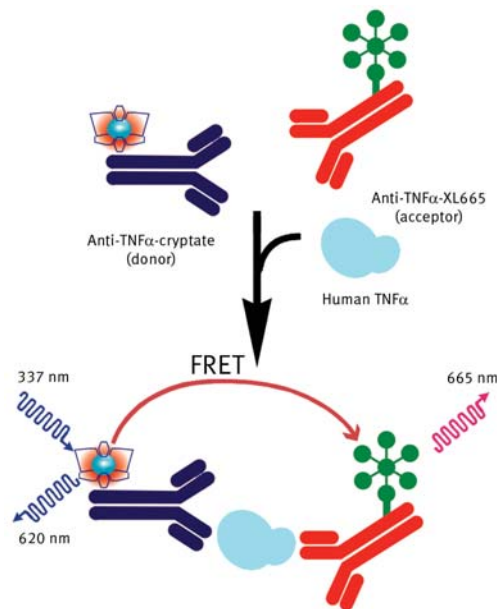

Fig. 8: Assay principle of the homogeneous time-resolved fluorescence immunoassay for TNFα. The assay is run using straightforward “mix & measure” detection.

Under its final configuration, free TNFα from calibrators or samples is sandwiched by mouse MAb IPM2-Eu cryptate (IPM2-K) and mouse MAB IPM3-XL665 (IPM3-XL665) conjugates. The FRET signal generated by the simultaneous binding of the two conjugates is proportional to the amount of TNFα present in the sample. Both 665 nm and 620 nm signals were measured simultaneously on the PHERAstar. Under routine use, the 665 nm / 620 nm fluorescence ratio (US patent 5,527,684) eliminates most interference from the medium.⁶ For a direct comparison of the PHERAstar with the RUBYstar, the samples were measured on both readers and the results are shown in Fig. 9.

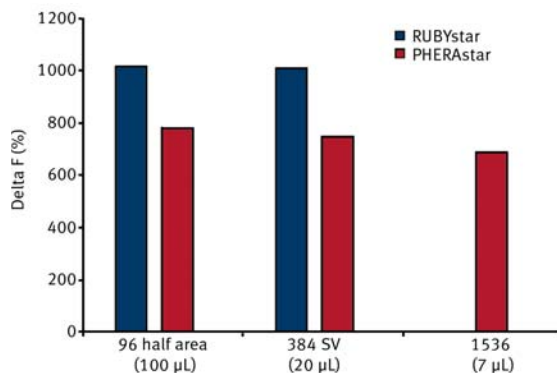

Fig. 9: Direct comparison of the PHERAstar and the RUBYstar in different plate formats using the HTRF® reader comparison kit (high calibrator, n = 8) based on a TNFα immunoassay.

Delta F is a value calculated from the 665 nm / 620 nm ratios which enables the data to be normalized with respect to between-assay variations. In addition, delta F is reader independent and can be used for indicating and comparing the quality of a reader.⁷ A total of five PHERAstars and two RUBYstars were compared to obtain these results. When comparing the PHERAstar to the RUBYstar, the PHERAstar shows approximately 20% less signal than the RUBYstar in terms of delta F in 96- and 384-well plates. However, the %CVs and signal separation obtained with the PHERAstar still results in an excellent delta F value and good HTRF[®] performance.

The results from the multimode PHERAstar reader proved that HTRF[®] assay miniaturization (100 µL to 7 µL) in plate formats up to 1536, has no significant influence on the excellent reader sensitivity, dynamic range, or %CVs (2%). In addition, we have shown that the already acknowledged “HTRF[®] compatible” reader PHERAstar can produce high quality data for HTRF[®] technology assays and is comparable to the dedicated RUBYstar (“the gold standard” reader for HTRF[®] assays) in terms of sensitivity. Due to the fact that the RUBYstar is designed for plate formats up to 384-wells, a direct comparison in 1536-well format was not possible. However, the data shows that the PHERAstar is capable of producing excellent results for HTRF[®], even in 1536-well mode, with no reduction in assay sensitivity.

Conclusion

The discovery of new leads through HTS is based on the ability to precisely measure biomolecular interactions and find successful detection strategies that are compatible with miniaturized HTS. Furthermore, the application of the time-resolved fluorescence mode in HTRF[®] assays, the shift to “red” fluorophores in PolarScreen[™] assays, and the use of AlphaScreen[™] assays have been recognized as useful strategies to overcome interference due to autofluorescence, light scatter due to precipitated compounds, or inherent detection mode noise. The PHERAstar multimode reader has a wide range of possible applications for HTS needs.

As shown in time-resolved fluorescence mode, the “HTRF[®] compatible” PHERAstar allows straightforward assay miniaturization to plate formats up to 1536 with no influence on the excellent sensitivity of the reader. This reduces the consumption of expensive reagents and provides significant cost savings. The PHERAstar also shows great performance in fluorescence polarization mode as demonstrated with the new homogeneous Far Red PolarScreen[™] assay for tyrosine kinase in 384-well low volume plate format. In AlphaScreen[™] mode the tyrosine kinase and the cAMP assay were tested with the PHERAstar resulting in excellent performance and read times in 384-well SV plate format.

The criteria used in selecting an HTS instrument should be cost, sensitivity, speed, flexibility, ease of use, and reliability. The PHERAstar fulfils all these criteria and the results in this application note prove that the PHERAstar is a robust and versatile multimode reader with excellent performance for HTS needs.

References

- 1) PolarScreen[™] Tyrosine Kinase Assay Kit, Far Red Protocol #PV3327, Invitrogen, USA.
- 2) AlphaScreen[™] Phosphotyrosine (P-Tyr-100) Assay Kit Protocol #6760620 and cAMP Assay Kit Protocol #6760625, PerkinElmer, USA.
- 3) HTRF[®] Reader Control Kit Protocol #62RCLPEA, Cisbio, France.
- 4) Zhang, J. *et al.* (1999) *J. Biomol. Screen.* **4**, 67-73.
- 5) Illy, C. *et al.*, Sci. Poster (#P01047), SBS 9th Annual Conference, (2003).
- 6) Degorce, F. *et al.*, HTRF[®] TNF α Kit Application Note 3, Cisbio, France.
- 7) Liu, J. *et al.*, (2004) *J. Biol. Chem.* **279**, 15824-30.

HTRF is a registered trademark of Cisbio.

The fluorescence ratio associated with the HTRF[®] readout is a correction method developed by Cisbio and covered by the US patent 5,527,684 and its foreign equivalents, for which Cisbio has granted a license to BMG LABTECH. Its application is strictly limited to the use of HTRF[®] reagents and technology, excluding any other TR-FRET technologies.

AlphaScreen is a trademark of PerkinElmer.

PolarScreen is a trademark of Invitrogen Corporation.

Headquarters:

Germany:	BMG LABTECH GmbH	Tel: +49 781 96968-0
Australia:	BMG LABTECH Pty. Ltd.	Tel: +61 3 59734744
China:	BMG LABTECH Co. Ltd.	Tel: +86 10 6424063
France:	BMG LABTECH SARL	Tel: +33 1 48862020
UK:	BMG LABTECH Ltd.	Tel: +44 1296 336650
USA:	BMG LABTECH Inc.	Tel: +1 919 806 1735
	www.bmglabtech.com	info@bmglabtech.com